

VAZ® 2000 M F FF

Vecoplan®



VAZ® 2000 M F FF Film Fiber Shredder

The VAZ® 2000 M F FF Rotary Shredder with the SureCut™ Cutting System is designed specifically for single-stage reduction of plastic films and synthetic fibers being reclaimed for extrusion. The FF Series is built for high throughput, has built-in metering capabilities and thermal monitoring controls. Benefits of the SureCut™ Cutting System include precise cut lengths and high bulk densities.

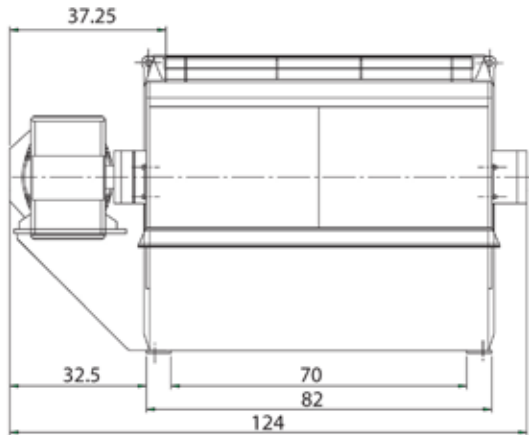

front view

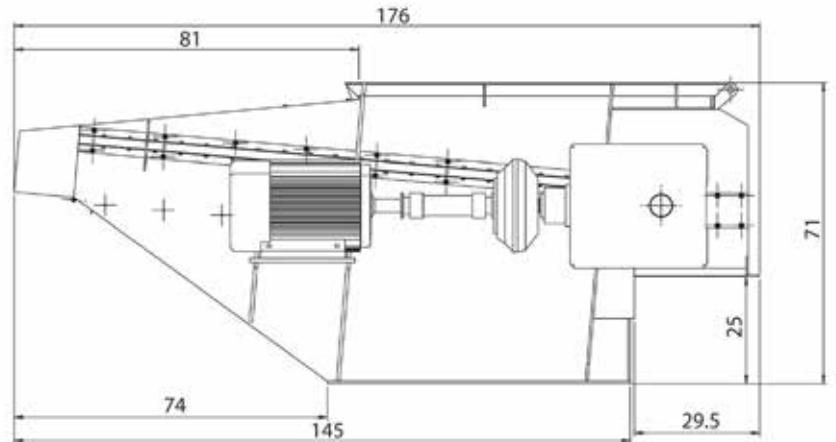

side view

Specifications

Hopper Opening	inch	78x78
Hopper Volume	cubic yards	*
Rotor Diameter	inch	25
No. of Cutters	qty	92 (std. 40x40) + 45 (nip)
Rotor Speed	rpm	120
Drive Motor HP	HP	200 - 300
Feed System	HP/speed	12.5 / 2
Machine Weight	lbs	39,683
Voltage	V/PH/Hz	460/3/60

Options

- Custom Hoppers
- Abrasion Resistant Screens
- Control Integration
- Air Spring Counter Knife
- Turn-Key Installation w/Custom Conveyor Systems Engineering and Material Handling Equipment

Features

- SureCut™ Cutting System
- Low Speed / High Torque Design
- PLC Controls / Touch Pad Monitoring
- Tramp Metal Protection
- Large Infeed Hopper
- Precision Hydraulic "Process Ram"
- Composite 4-Way Indexable Cutting Inserts
- Rugged Hydraulics
- Lifetime Limited Warranty on Cutting Rotor
- Oversized Spherical Roller Bearings
- Fluid TurboCoupling
- ISO 9001 Manufactured
- Hinged Protective Cylinder Covers
- 0.015 Knife Gap for Thin Materials
- Easy Access Screen
- Critical Duty Drivetrain
- Passive Programming for Self-Feed Materials
- Wear Resistant Siderails & Cutting Chamber
- Reinforced Screens
- Heavy Viscosity Fluids
- Diverter Plate Over Cutting Rotor
- Built-In Rotor Thermal Monitoring Controls