

# VVZ 300

TECHNOLOGY FOR A SUSTAINABLE TOMORROW



Shredding



## APPLICATION

The Vecoplan VVZ 300 Rotary Shredder is designed especially for bulk size reduction of old timber and wood waste.

## FEATURES

- Airspring Counterknife simplifies removal of tramp material and simplifies maintenance
- Center anvil with replaceable hard-faced counterknife and removeable screen grates
- Changeable resizing screens add economical production of consistent sized particles in one pass

[www.vecoplanllc.com](http://www.vecoplanllc.com)

**Vecoplan**<sup>®</sup>

# VVZ 300

TECHNOLOGY FOR A SUSTAINABLE TOMORROW



Shredding

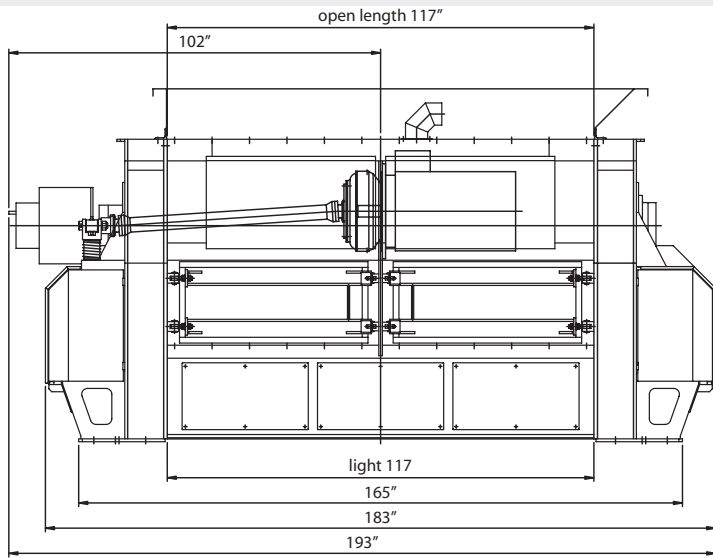

front view

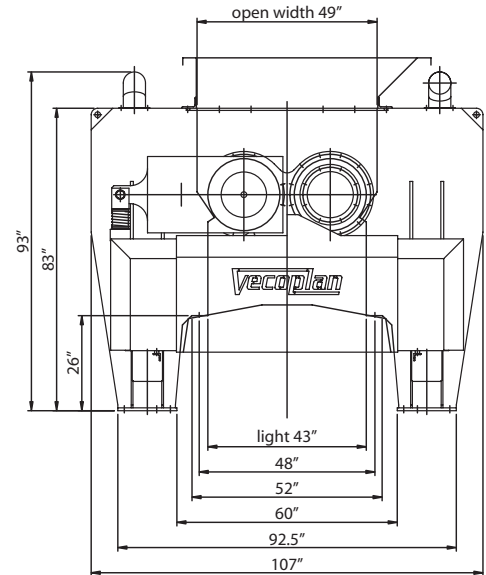

side view

## SPECIFICATIONS

Hopper Opening	inch	50 x 117
Hopper Volume	Type	*
Rotor Diameter	inch	20
No. of Cutters	qty	2x 27 (80mm x 80mm)
Rotor Speed	rpm	95 / 75
Drive Motor HP	HP	2x 100 / 75
Feed System	*	*
Machine Weight	lbs	34,172
Voltage	V/PH/Hz	460/3/60

## OPTIONS

- Special Screen Gate
- Optional Hopper Designs

Vecoplan, LLC  
 P.O. Box 7224 • High Point, NC 27264  
 Phone: 336•861•6070 Fax: 336•861•4329

www.vecoplanllc.com  
 0209A

