

# Vecoplan Material Handling Discharge Conveyors

## *RMH Series*

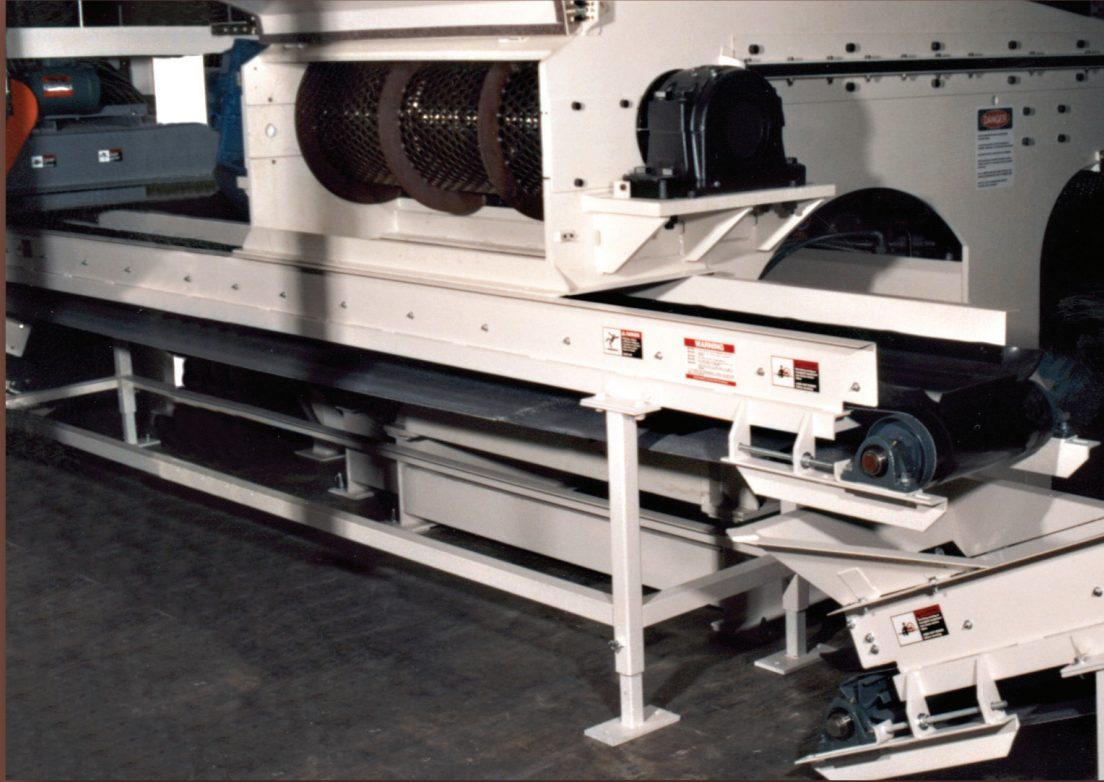

### *RD-16/12-16-24*

- Rubber sidewall skirting contains material on belt
- Adjustable support legs with mounting pads
- PVC belting with rubber cleats at 24" centers
- Dimensions: 12', 16', 24' lengths, 16" wide, 6" sidewalls
- Standard belt speed: 94 fpm
- Heavy duty crowned head and winged tail pulleys
- Tail pulley cover
- 1 HP TEFC motor, 230/460V, 3 PH, 60 HZ
- Maximum load / full load capacity: 1,500 lbs

Horizontal conveyors used to convey shredded material away from size reduction equipment

## ***Vecoplan***

*sustainable technology*

THE ULTIMATE SHREDDING MACHINE

# Discharge Conveyors

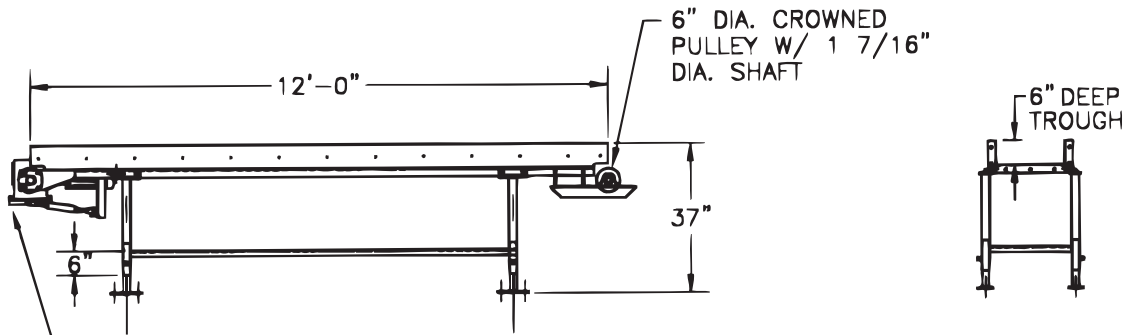

1 HP. DODGE 262 GEARMOTOR  
30:1 RATIO AT 92 FPM.  
6" DIA. CROWNED PULLEY  
W/ 1 7/16" DIA. SHAFT

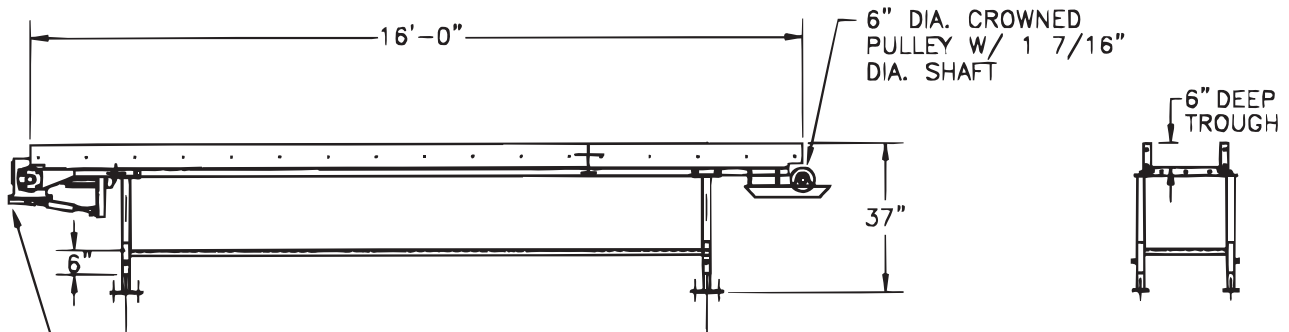

1 HP. DODGE 262 GEARMOTOR  
30:1 RATIO AT 92 FPM.  
6" DIA. CROWNED PULLEY  
W/ 1 7/16" DIA. SHAFT

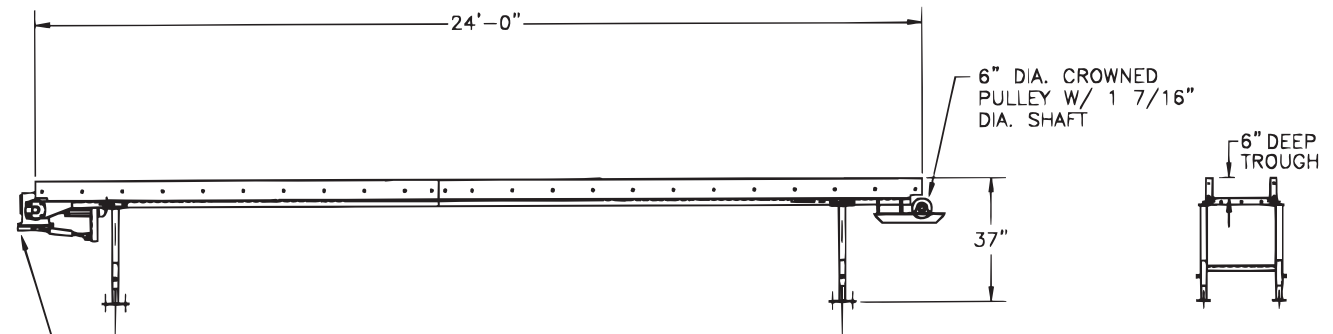

1 HP. DODGE 262 GEARMOTOR  
30:1 RATIO AT 92 FPM.  
6" DIA. CROWNED PULLEY  
W/ 1 7/16" DIA. SHAFT

## *Vecoplan*

*sustainable technology*

P.O. Box 7224 • High Point, NC 27264  
Phone: (336) 861-6070 • Fax: (336) 861-4479  
[www.VecoplanLLC.com](http://www.VecoplanLLC.com)